

# GROVE GMK 3050

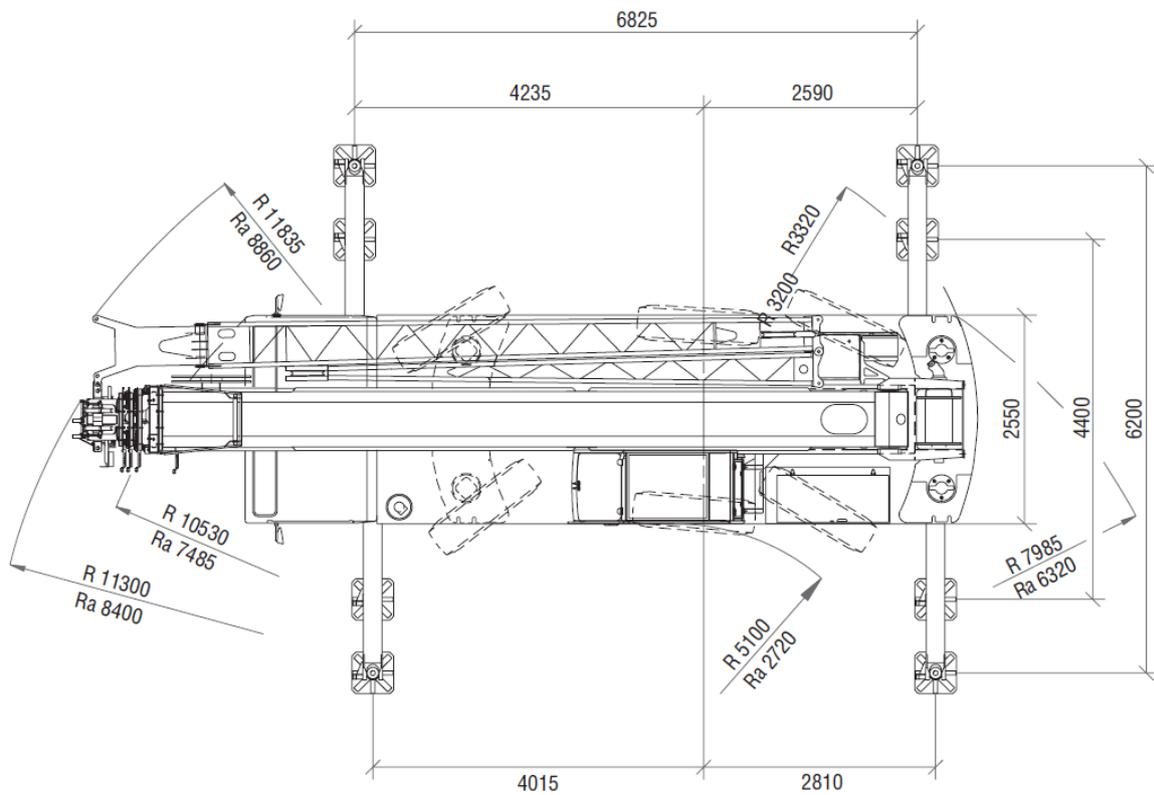

Onze middelen en onze filosofie garanderen uw resultaat!

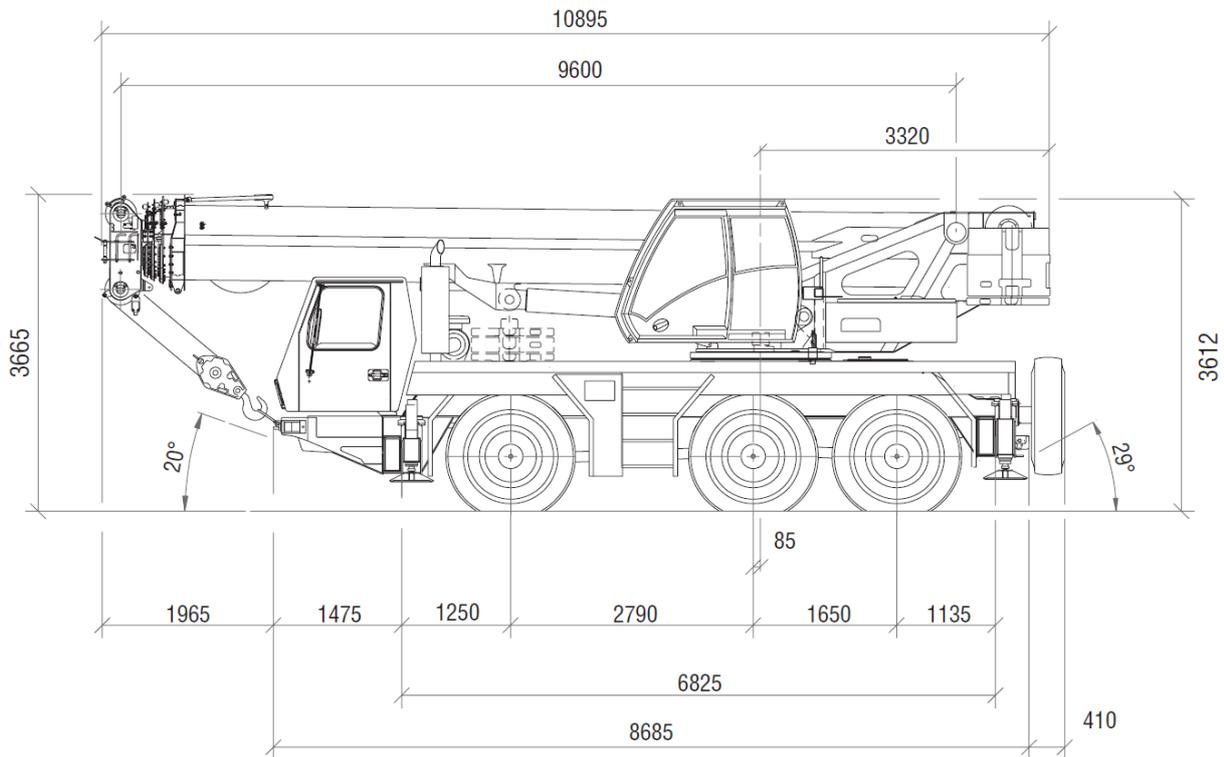

9,6 – 38,0 m



8,7/15 m



6,2 m



360°

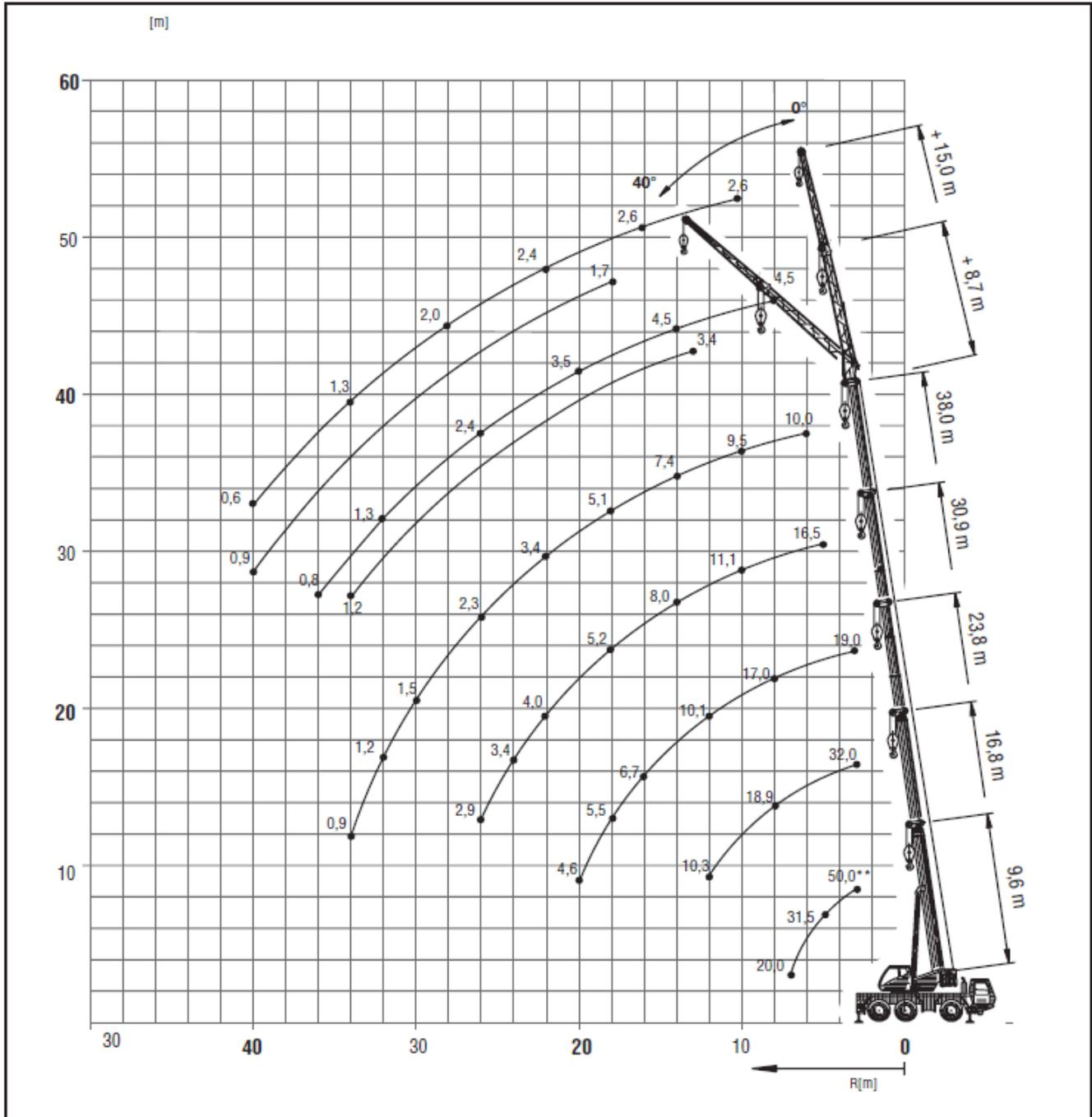



9,6 – 38,0 m



6,2m



360°



8,6 t



DIN/ISO

| m    | 9,6        | 13,2 | 16,8 | 20,3 | 23,8 | 27,3 | 30,9 | 34,4 | 38,0 |
|------|------------|------|------|------|------|------|------|------|------|
| 3,0  | 50,0*/44,5 | 41,5 | 32,0 | 19,0 | 19,0 |      |      |      |      |
| 4,0  | 37,0       | 35,0 | 28,5 | 19,0 | 19,0 | 18,0 |      |      |      |
| 5,0  | 31,0       | 30,5 | 25,0 | 19,0 | 19,0 | 18,0 | 16,5 | 12,7 |      |
| 6,0  | 25,0       | 24,5 | 21,5 | 19,0 | 19,0 | 17,6 | 16,0 | 12,7 | 10,0 |
| 7,0  | 20,0       | 20,5 | 19,0 | 19,0 | 18,3 | 15,8 | 14,7 | 12,7 | 10,0 |
| 8,0  |            | 17,4 | 17,7 | 16,1 | 15,6 | 14,2 | 13,4 | 12,2 | 10,0 |
| 9,0  |            | 14,2 | 14,6 | 14,6 | 13,3 | 13,0 | 12,0 | 11,4 | 10,0 |
| 10,0 |            | 11,8 | 12,2 | 12,4 | 11,5 | 11,3 | 10,7 | 10,3 | 9,5  |
| 11,0 |            |      | 10,3 | 10,6 | 10,0 | 9,9  | 9,7  | 9,0  | 8,9  |
| 12,0 |            |      | 8,9  | 9,2  | 9,1  | 8,7  | 8,6  | 8,2  | 7,9  |
| 13,0 |            |      |      | 8,0  | 8,2  | 7,7  | 7,7  | 7,6  | 7,0  |
| 14,0 |            |      |      | 7,1  | 7,2  | 7,2  | 6,9  | 6,8  | 6,3  |
| 15,0 |            |      |      | 6,3  | 6,4  | 6,5  | 6,2  | 6,1  | 5,6  |
| 16,0 |            |      |      | 5,6  | 5,7  | 5,8  | 5,8  | 5,5  | 5,0  |
| 18,0 |            |      |      |      | 4,6  | 4,7  | 4,8  | 4,5  | 4,1  |
| 20,0 |            |      |      |      |      | 3,9  | 4,0  | 3,6  | 3,3  |
| 22,0 |            |      |      |      |      |      | 3,2  | 2,9  | 2,7  |
| 24,0 |            |      |      |      |      |      | 2,7  | 2,4  | 2,1  |
| 26,0 |            |      |      |      |      |      |      | 2,0  | 1,7  |
| 28,0 |            |      |      |      |      |      |      |      | 1,3  |
| 30,0 |            |      |      |      |      |      |      |      | 1,0  |
| 32,0 |            |      |      |      |      |      |      |      | 0,7  |

\* 0° over naar, nach hinten, en arrière, por la parte trasera, sul posteriore.